

## xBALL - DATA SHEET

**xBALL 1.0 vers. A3 - actuated control ball valve, 0/10V signal operated**

- › HFC, HFO and R290 refrigerant compatible
- › For flammable refrigerants of safety group A3 (ISO 817)
- › Perfect seal closure
- › Suitable for refrigerant flow control
- › Nominal voltage AC/DC 24 V
- › IP40
- › Feedback signal 0...10V
- › Safety closure with supercap



### Product range

Cod. with supercap	Description
BEA01D16D16YA3	Actuated control ball valve, 0...10V, 15 s, Kvs 1,2, 16-16 mm ODF connections, 3 mt cable, A3
BEA04D16D16YA3	Actuated control ball valve, 0...10V, 15 s, Kvs 4,8, 16-16 mm ODF connections, 3 mt cable, A3
BEA08D22D22YA3	Actuated control ball valve, 0...10V, 15 s, Kvs 8, 22-22 mm ODF connections, 3 mt cable, A3
BEA01D28D28YA3	Actuated control ball valve, 0...10V, 15 s, Kvs 1,2, 28-28 mm ODF connections, 3 mt cable, A3
BEA04D28D28YA3	Actuated control ball valve, 0...10V, 15 s, Kvs 4,8, 28-28 mm ODF connections, 3 mt cable, A3
BEA04D35D35YA3	Actuated control ball valve, 0...10V, 15 s, Kvs 4,8, 35-35 mm ODF connections, 3 mt cable, A3
BEA08D42D42YA3	Actuated control ball valve, 0...10V, 15 s, Kvs 8, 42-42 mm ODF connections, 3 mt cable, A3

### Technical data

<b>Electrical data</b>	Nominal voltage	AC/DC 24V
	Nominal voltage frequency	50/60 Hz
	Nominal voltage range	AC 19.2 ... 28.8 V / DC 21.6 ... 28.8 V
	Power consumption in operation	2,5 W
	Power consumption in rest position	0,5 W
	Power consumption for wire sizing	5 VA
<b>Working data</b>	Connection supply / control	Cable 3 m, 4 x 0,34 mm <sup>2</sup>
	Running time motor	15s / 90° (typical)
	Sound power level motor	35dB(A)
	Position indication	Mechanical
	Position feedback U	0,5V ... 10 V
	Operating range Y	0,5V ... 10 V
	Input impedance	100 kΩ
	Compatible refrigerants	HFC, HFO*
	Fluid temperature	-20°C ...70°C
	Maximum pressure Ps	50 barg
	Maximum differential pressure Δpmax	35 barg
	Flow characteristic	Equal percentage (VDI/VDE 2178)
	Leakage rate with closed valve	Leakage rate A: air bubble tight (EN 12266-1)
	Connection	Solder
Position of installation	From vertical to horizontal	
Maintenance	Not necessary	

## Technical data

### Control general data

Controlling scope	Valve positioning / control
Controlling installation	Independent mounting
Cable removal	Cables may be removed by qualified technicians (manufacturer or authorized service center) only
Type of movement	Rotary (90° adjustable)
Maximum rated mechanical load	1,0 Nm
Maximum angular rotation	90°

### Safety

Protection class IEC/ EN	III, Safety Extra-Low Voltage (SELV)
Index of protection IEC/EN	IP40
Directives RoHS (2015/863/EU), RED (2014/53/EU), PED (2014/68/EU), LVD (2014/35/EU), EMC (2014/30/EU)	Compliant
Compatible refrigerants	R1234ze, R134a, R404A, R407C, R407H, R410A, R417A, R427A, R448A, R449A, R450A, R507A, R452A, R513A, R1234yf, R32, R452B, R454A, R454B, R454C, R455A, R290
Flammable refrigerants	The product is not to be considered a source of ignition when used together with A2L and A3 classified refrigerants and is compliant against clauses 22.116 and 22.117 from IEC 60335-2-40. Compliance against cl. 22.117 is checked by measuring the appropriate surface temperatures during the tests of IEC 60335-2-40, Clauses 11 and Clauses 19. The maximum surface temperature of the devices and components does not exceed the temperature limit of 370 °C.
Operation type	Type 1
Pollution degree	2
Ambient temperature	-30°C ... +60°C (without irradiation)
Storage temperature	-40°C ... +80°C
Maximum ambient humidity	95% RH, non-condensing
Heat and fire strength	Category D
Overvoltage category	Category III
Rated impulse voltage supply	0,8 kV
Software class and structure	A

## Safety tips



- The device has been designed to be used for stationary refrigeration equipment ventilation and air conditioning systems. Usage is not permitted outside the foreseen application fields, especially on airplanes or any kind of airplane transport.
- External application: only possible if it is not in direct contact with sea water, snow, ice, heating or aggressive gases at direct contact with the actuator. The environmental conditions should remain any time within the limits indicated in the technical data sheet.
- The installation can only be carried out by authorized technicians. All applicable legal or institutional regulations must be respected.
- The device can only be opened at the manufacturing site. It does not contain parts repairable or replaceable by the user.
- The device contains electrical and electronic components and cannot be disposed of in normal household waste. All local disposal regulations must be observed.
- Acceptability of these products in end use application where flammable refrigerants are used shall be reviewed and judged in the end use application.

## Product features

### Selection

Bereva recommends its sizing software, that is free to download from Bereva web site.

### Working concept

The actuator relates to a standard control signal of 0...10 V and drives to the position defined by the control signal. Measuring voltage U serves for the electrical display of the valve position 0.5...100% and as control signal for other actuators. The opening of the ball valve is counterclockwise and closing clockwise.

### Start up time

The devices with the emergency closing function require a pre-charge time. This time is used to charge the capacitors to the necessary level. That ensures that, in the event of a power failure, the actuator can move in each moment from its current position to the fully closed position. The time of pre-charge mainly depends on the duration of the power failure. Nominal pre-charge time goes from 6 seconds for interruptions of less than 24 hours, to 14 seconds for interruptions of more than 12 days.

### Friendly installation

Snap-on assembly without tools. The actuator is installed on the valve with the simple pressure of the hands (Attention! vertical movement only). The pins must match the holes on the flange. The actuator mounting position on the valve can be selected in 180° steps. The actuator is protected from overload, does not require electrical limit switches and stops automatically when reaching the mechanical stops.

### Manual action

Only in case of need and in compliance with the operating conditions of the refrigeration circuit and its components, remove the actuator and rotate the valve stem with the help of the Belimo ZCQ-FL accessory.

### Flow setting

Remove end stop clip and place at desired position. After every change of the flow setting by means of end stop clip, an adaptation must be triggered on the modulating actuators.

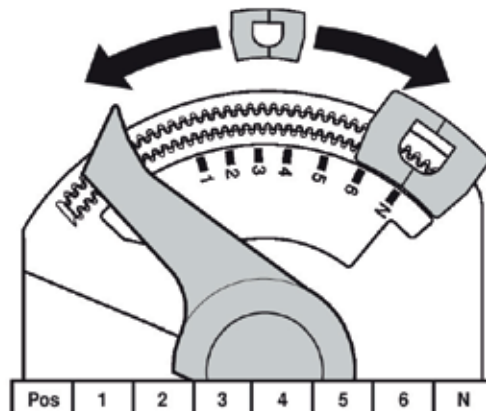

## Wiring Connections

**Wiring diagrams:**  
AC/DC 24 V, modulating

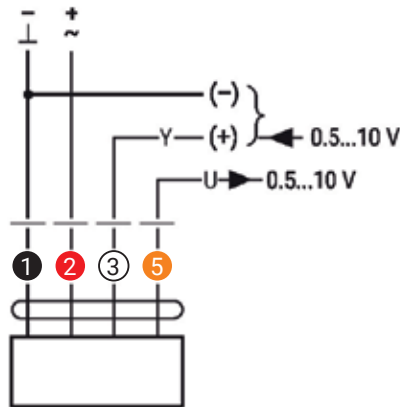

Override control  
(frost protection circuit)

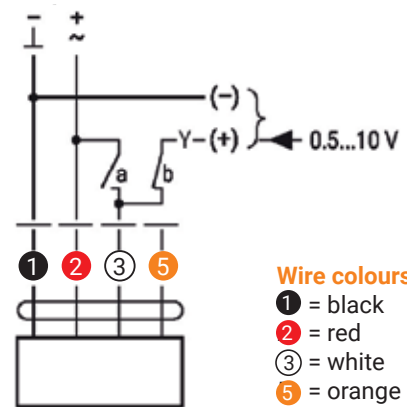

**Wire colours:**

- ① = black
- ② = red
- ③ = white
- ⑤ = orange



Supply from isolating transformer. Parallel connection of other actuators possible. Observe the performance data.

1	2	3 (a)	3 (b)		
				A - AB = 100%	
				A - AB = 0%	
				0.5...10 V	

## Configuration and led indicator

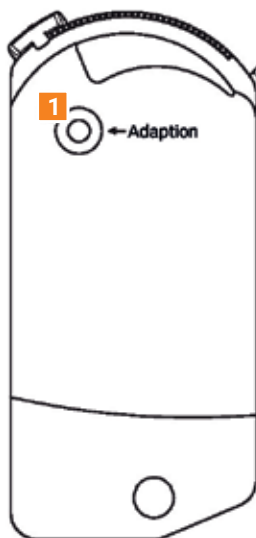

**1 Push-button**

Press button: Triggers angle of rotation adaptation, followed by standard mode.

## Dimensions (mm)

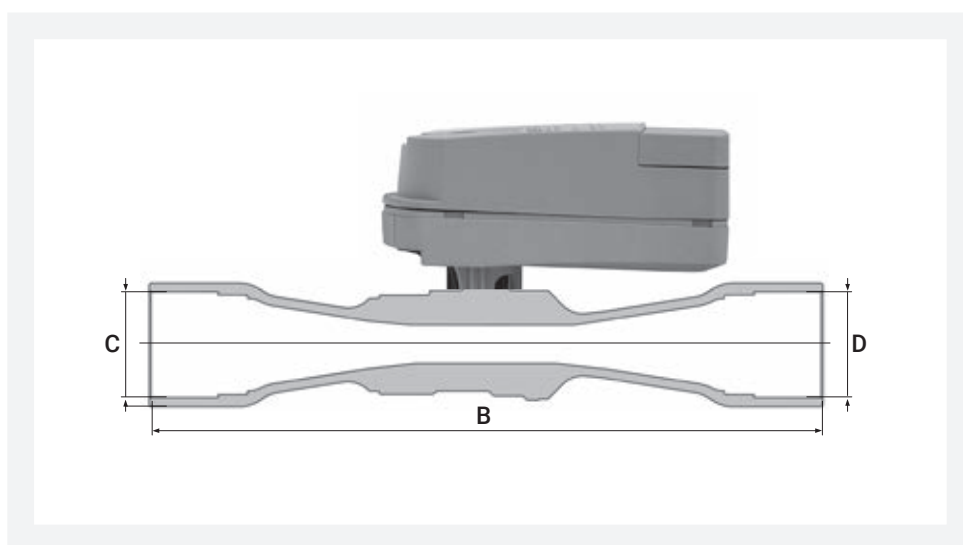
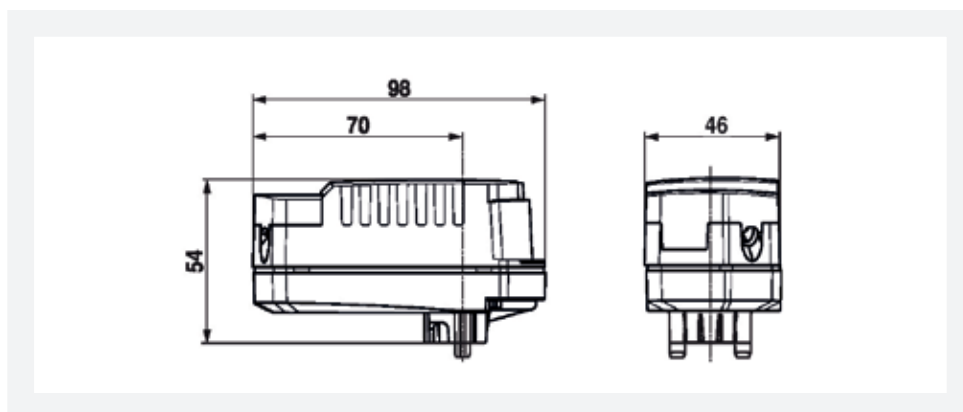

Valve model	B	C	D	Depth*
BEA01D16D16...	180	16	16	50
BEA04D16D16...	180	16	16	50
BEA08D22D22...	190	22	22	50
BEA01D28D28...	180	28	28	50
BEA04D28D28...	180	35	35	50
BEA04D35D35...	180	35	35	50
BEA08D42D42...	190	42	42	50

The representation of the dimensions on the drawing is valid for all available models